

# SEQUENCE<sup>®</sup> 8000 / 10,000 / 12,000

## INSTALLATION AND SERVICE MANUAL



Please fill in for future reference:

MODEL: \_\_\_\_\_

SERIAL NUMBER: \_\_\_\_\_

DATE PURCHASED: \_\_\_\_\_

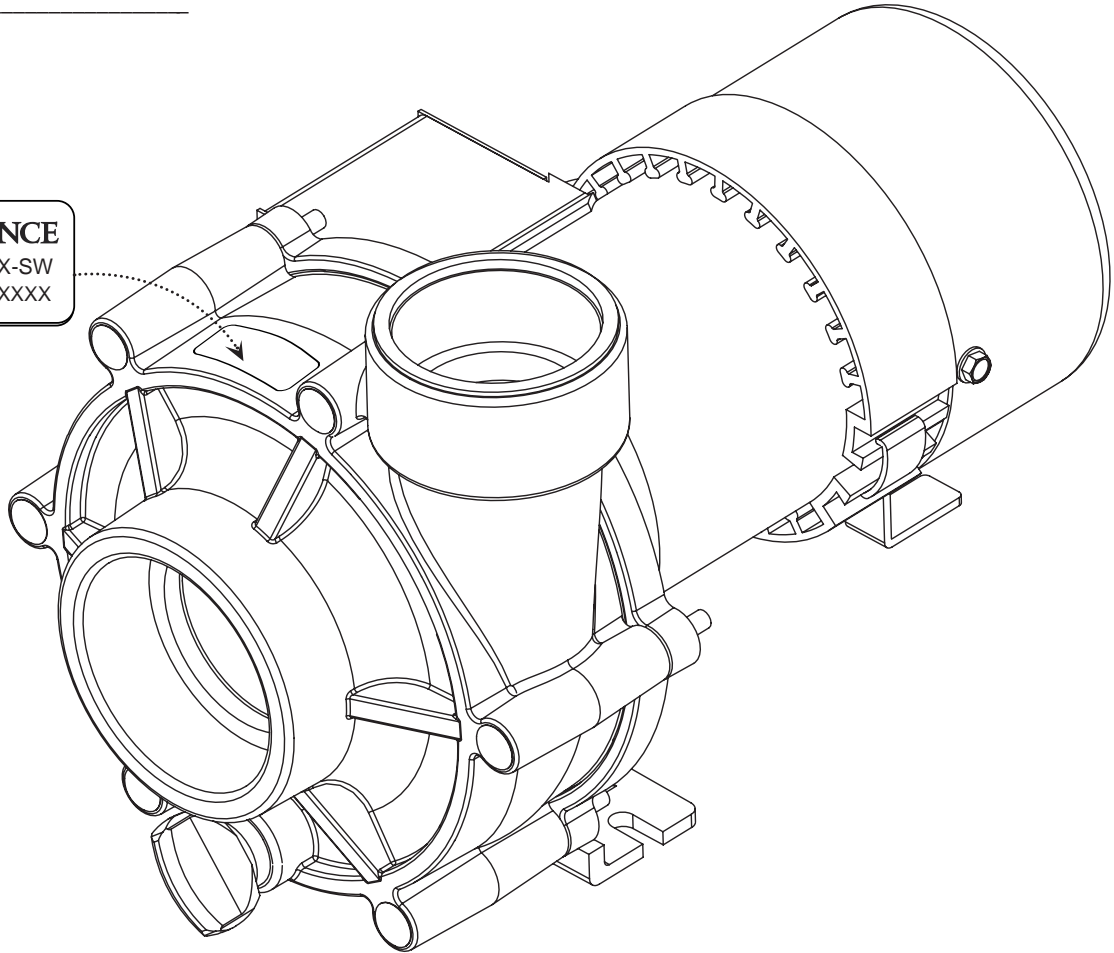
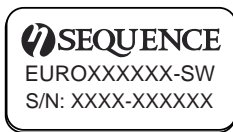

**WARNING: PLEASE READ COMPLETELY BEFORE YOU INSTALL OR OPERATE YOUR NEW PUMP!**

This is an external “out-of-pond” pump. It is **NOT** submersible. Protect from rainfall and frost. Do **NOT** allow this pump to become submerged. Never run dry. Max. case pressure. - 25 PSI.

Model	SEQUENCE 8000	SEQUENCE 10,000	SEQUENCE 12,000
INLET	2"	2"	2"
OUTLET	1.5"	1.5"	1.5"
MAX FLOW (gph)	1760	2200	2640
MAX FLOW (litres per hour)	8000	10,000	12,000
MAX HEAD (metres)	2.4m	2.4m	2.5m

**Sustainable, Efficient.**

# SEQUENCE<sup>®</sup> 8000 / 10,000 / 12,000

We congratulate you on your choice of the Sequence<sup>®</sup> 8000 / 10,000 / 12,000 centrifugal pump! (Also referred to as the Sequence<sup>®</sup> 750 pump range). Its leading edge design provides you with high output at a minimal operating cost. It is carefully constructed to give you long term, reliable service. To insure proper performance, we urge you to carefully follow the instructions in this manual. If you have any questions, please call your Evolution Aqua Dealer for assistance.

## INSTALLATION

Please read carefully! When properly installed, the Sequence<sup>®</sup> 8000 / 10,000 / 12,000 pumps will provide dependable, trouble-free service.

1. Do not submerge the unit in water - it is not a submersible pump. Do not allow the pump to become submerged during transient periods, such as heavy rain, run-off, etc.
2. Locate the pump as near the water source as possible. We recommend a flooded suction installation. **IT MUST NOT BE RUN DRY.**  
**PLEASE READ CAREFULLY:** No air intake into the pump.
3. The pump is not self-priming. Therefore, if the water level is below the pump, a non-return valve must be installed below water level. The pump and inlet line must be primed prior to start up. For non-flooded installations, a strainer basket and check valve are recommended.
4. Mount the motor base to a secure, immobile foundation.
5. Use only plastic fittings on both the inlet and discharge ports. Seal the inlet & discharge fittings with PTFE tape. These fittings should be self-supported and in neutral alignment with each port (i.e., Fittings must not be forced into port alignment which may cause premature line failure or damage to the pump volute).
6. Never restrict the inlet! Keep both inlet and discharge lines as free of elbows and valves as possible. Always use pipe of adequate diameter. This will reduce friction losses and maximize output. Never use an inlet line of smaller diameter than the discharge line. Minimize the suction lift.
7. Always protect your pump from rainfall.

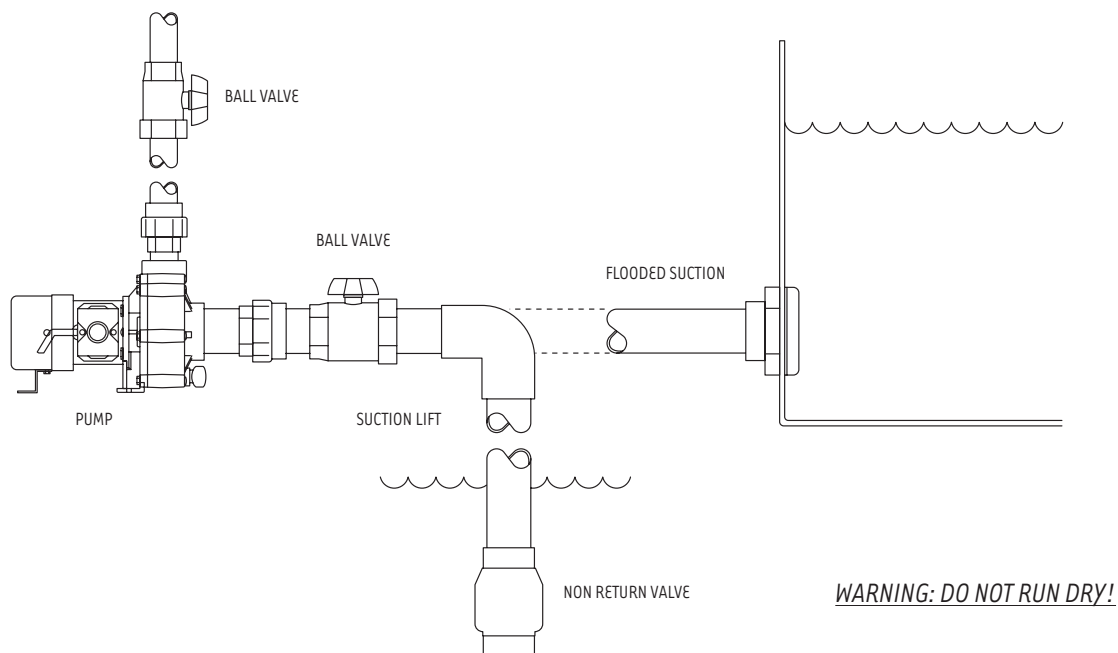

**WARNING: ALWAYS SHUT OFF ELECTRICAL POWER BEFORE INSTALLATION AND / OR SERVICING THIS PUMP! ELECTRICAL INSTALLATIONS MUST BE DONE BY A QUALIFIED ELECTRICIAN. A RESIDUAL CURRENT DEVICE (RCD), ALSO KNOWN AS THE RESIDUAL CURRENT CIRCUIT BREAKER (RCCB), WITH A TRIPPING CURRENT NOT EXCEEDING 30mA MUST BE INSTALLED IN THE SUPPLY CIRCUIT. A MEANS OF DISCONNECTION FROM THE SUPPLY HAVING A CONTACT SEPARATION OF AT LEAST 3MM IN ALL POLES MUST BE INCORPORATED IN THE WIRING.**

## ELECTRICAL HOOK-UP

CAREFULLY, EXAMINE THE POWER CORD BEFORE USE. DO NOT USE THIS POWER CORD IF THERE IS ANY VISIBLE DAMAGE. DO NOT USE THIS POWER CORD IN WATER OR IF THE MOTOR OR ELECTRICAL RECEPTACLE IS IN CONTACT WITH ANY STANDING WATER! THIS POWER CORD SHOULD ONLY BE PLUGGED INTO A PROPERLY INSTALLED RCD! ALWAYS TEST CYCLE A RCD TO DETERMINE ITS CONDITION BEFORE USE!

**Sustainable, Efficient.**

# SEQUENCE® 8000 / 10,000 / 12,000

## PUMP END ASSEMBLY

1. Inspect all pump parts (O-ring, O-ring groove, impeller hub ID, motor shaft, etc.) and clean if necessary.
2. Apply silicone sealant to the bracket bore ID wall and around the seal case - follow sealant mfg. instructions.
3. Press the carbon graphite seal into the bracket while taking care not to touch or damage the carbon graphite face. Never touch or apply pressure to the carbon graphite seal face!
4. Screw four M-Bolts five complete turns into the threaded holes located on the motor face.
5. Mount the bracket to the motor by aligning the key holes over each bolt head, then rotate clockwise which will position the small key hole slot under each bolt head. Tighten each bolt with a wrench to secure the bracket to the motor (8-25 lb. in.).
6. Carefully, lubricate the seal seat elastomer OD and impeller hub ID with water. Press the seal seat into the impeller hub making certain that the ceramic is in evenly - the sealing surface should be parallel with the impeller hub.
7. Apply CLEAN water to the carbon-graphite and seal seat sealing surfaces. Do not use silicon lubricants or grease!
8. Lock the shaft by placing a screwdriver blade into the shaft slot at the fan end of the motor. Thread the impeller onto the motor shaft. Thread until the washer securely contacts the shaft shoulder.
9. Seat the large O-ring into the bracket O-ring groove.
10. Assemble the volute onto the bracket with six P-Bolts (10-24 x 2 3/4" carriage bolts) and six flanged lock nuts. Tighten in a cross pattern (30 lb. in.).
11. Install the drain plug and O-ring, into the volute drain hole.
12. Before operating the Sequence® pumps, allow a proper cure time for the sealant used in step 2.

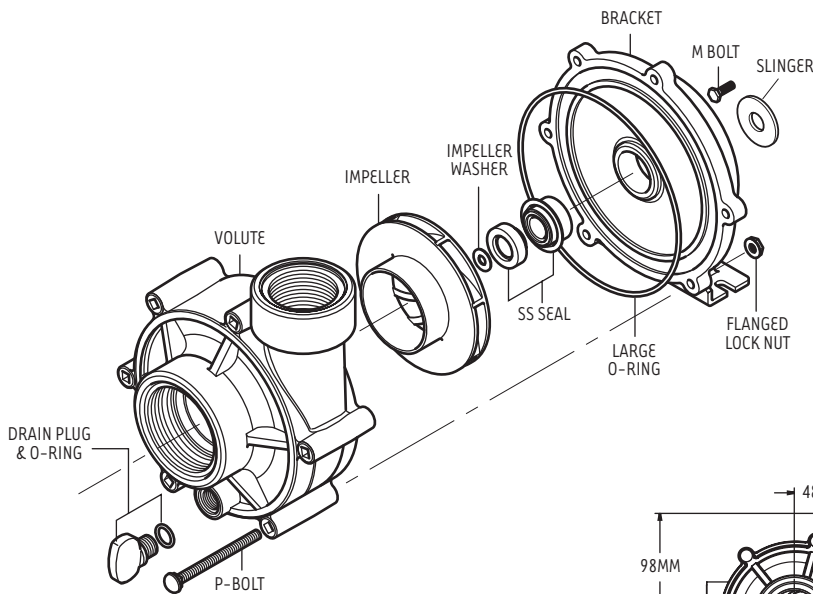

DESCRIPTION	EVOLUTION AQUA PART NUMBER:
DRAIN PLUG + O-RING	1000.111
VOLUTE	750.070LG
LARGE O-RING	750.061
IMPELLER 8000	750.055
IMPELLER 10,000	750.058
IMPELLER 12,000	750.059
SS SEAL KIT	750.0414
BRACKET	750.030LG
HARDWARE KIT	750.502
SLINGER	750.010

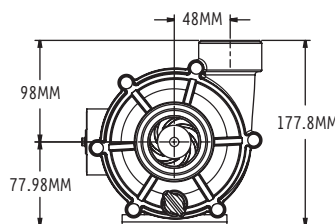

Motor illustration is for reference only.

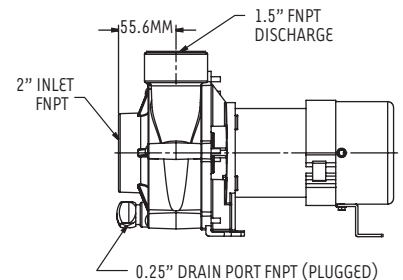

## DISASSEMBLY

1. Shut off power to the motor before servicing any pump!
2. Unplug the power cord.
3. Disassemble the volute from the bracket - six P-Bolts and six flanged lock nuts. The volute may remain attached to the plumbing to help simplify re-installation.
4. Lock the shaft by placing a screwdriver blade into the shaft slot at the fan end of the motor. Unthread the impeller from the motor shaft - Take care not to misplace the small metal impeller washer.
5. Remove the ceramic, with rubber boot, from the impeller hub (if you are replacing the seal).
6. Loosen the four M-Bolts attaching the bracket to the motor. Rotate the bracket counter-clock wise until the screw heads are located in the large key hole slots. Lift off the bracket from the motor.
7. Remove the carbon-graphite seal assembly from the bracket by pressing it out from the motor-side of the bracket. Do not pry it out with a screwdriver from the pump cavity-side of the bracket (if you are replacing the seal)!

**Sustainable, Efficient.**

# SEQUENCE<sup>®</sup> 8000 / 10,000 / 12,000

## MAINTENANCE

### Lubrication

Motor - Permanently Lubricated ball bearings - no service required.

Rotary Seal - Requires no lubrication after assembly.

*\*The pump must be drained before servicing or if stored below freezing temperatures. Periodic replacement of seals may be required due to normal carbon wear.*

Symptom	Problem	Resolution
No Flow	Insufficient Prime	Prime system with water and purge all air from suction piping.
		Install non return valve.
	Insufficient Power	Verify power supply and connection from panel to pump.
		Verify proper voltage. Some models are dual voltage (115/230).
	Flow Restriction	Ensure valves are open.
		Ensure plumbing is clear, including suction strainers, check valves, etc.
		Verify non return valve orientation and direction of permitted flow.
Air leak	Clean out leaves or other debris from basket strainer (if applicable).	
Air leak	Fix air leaks at fittings, connections, strainer basket etc. This typically occurs on the intake side.	
System Incompatibility	Verify hydraulic compatibility: i.e. pump & pipe are sized for the system.	
Low Flow	Air leak	Fix air leaks at fittings, connections, strainer basket etc. This typically occurs on the intake side.
	System Incompatibility	Verify hydraulic compatibility: i.e. pump & pipe are sized for the system.
	Insufficient Power	Verify power supply and connection from panel to pump.
		Verify proper voltage. Some models are dual voltage (115/230).
	Flow Restriction	Ensure valves are open.
		Ensure plumbing is clear, including suction strainers, check valves, etc.
		Clean out leaves or other debris from basket strainer (if applicable).
	Insufficient Prime	Prime system with water and purge all air from suction piping.
	Cavitation	Verify airtight plumbing on the suction plumbing especially fittings!
		Clean out leaves or other debris from basket strainer (if applicable).
Increase pipe size where possible.		
Decrease suction pipe length, reduce the number of elbows, etc.		
Sporadic Operation	Verify hydraulic compatibility: i.e. pump and pipe are sized for the system.	
	Verify power supply and connection from panel to pump.	
Excessive Noise	Insufficient Power	Verify proper voltage. Some models are dual voltage (115/230).
		Ensure adequate airflow over motor to prevent overheating.
	Cavitation	Verify airtight plumbing on the suction plumbing especially fittings!
		Clean out leaves or other debris from basket strainer (if applicable).
		Increase pipe size where possible.
		Decrease suction pipe length, reduce the number of elbows, etc.
	Insufficient Power	Verify hydraulic compatibility: i.e. pump and pipe are sized for the system.
		Verify power supply and connection from panel to pump.
	Flow Restriction	Verify proper voltage. Some models are dual voltage (115/230).
		Ensure valves are open.
Ensure plumbing is clear, including suction strainers, check valves, etc.		
		Verify non return valve orientation and direction of permitted flow.

**Sustainable, Efficient.**

# SEQUENCE<sup>®</sup> 8000 / 10,000 / 12,000

## GUARANTEE



Sequence Pumps are designed to give you many years of trouble free use, when operated under normal conditions.

**Sequence Pumps are not for submersible use.  
Sequence pumps are not weatherproof, and should be protected at all times  
Failure to do so could invalidate your warranty**

Your pump is covered against defects in manufacture and materials for a period of 3 years, subject to the following conditions;

The Pump must be installed, operated and regularly maintained in accordance with the instruction manual.

Any repairs or spare parts fitted during the warranty period must be undertaken by Evolution Aqua Ltd or its authorised representatives.

- It is the customer's responsibility to return the pump, at their cost, together with a valid proof of purchase, along with a brief description of the fault and any other relevant information, to Evolution Aqua at the address below. Evolution Aqua will not be liable for the costs of returning the pump to our technical department, and accepts no responsibility for damage during transit or consequential loss relating to this.

Before returning any pump for warranty appraisal, you must contact Evolution Aqua to obtain a customer returns number (CRN number). Please quote this CRN number on all correspondence and ensure that the pump has this number clearly marked.

Evolution Aqua will examine the pump, and if the fault is covered by the warranty, will repair and return to the customer at the earliest opportunity. The cost of returning the pump to the customer will be met by Evolution Aqua.

If the Sequence pump is found not to be covered by the warranty, we will contact you and, if it is possible to repair your pump, give you a quote for repairing and shipping it back to you.

Evolution Aqua will not guarantee the Sequence pump:-

When the fault is due to misuse or when unauthorised repairs have been attempted.

If adequate steps have not been taken to protect the pump from water getting into the electrics on the pump.

When the fault is due to fire or any other natural cause, including frost damage.

This warranty is not transferable.

Evolution Aqua Ltd. accepts no responsibility or liability for any consequential loss caused by or arising from the use of any Evolution Aqua products. Therefore, any dispute arising from the provisions of the warranty will be dealt with under the laws of England and Wales subject to the exclusive jurisdiction of the English Courts.

**Sustainable, Efficient.**

 **SEQUENCE<sup>®</sup> 8000 / 10,000 / 12,000**

EVOLUTION  
AQUA

**EVOLUTION AQUA LTD.**

Evolution House, Kellet Close, Wigan WN5 0LP

tel: +44 (0)1942 216554 fax: +44 (0)1942 216562

The difference is clear at [www.evolutionaqua.com](http://www.evolutionaqua.com)

**Sustainable, Efficient.**