

Applications:

- As a particle remover directly next to the pond or to a waterfall / stream return to pond (A).

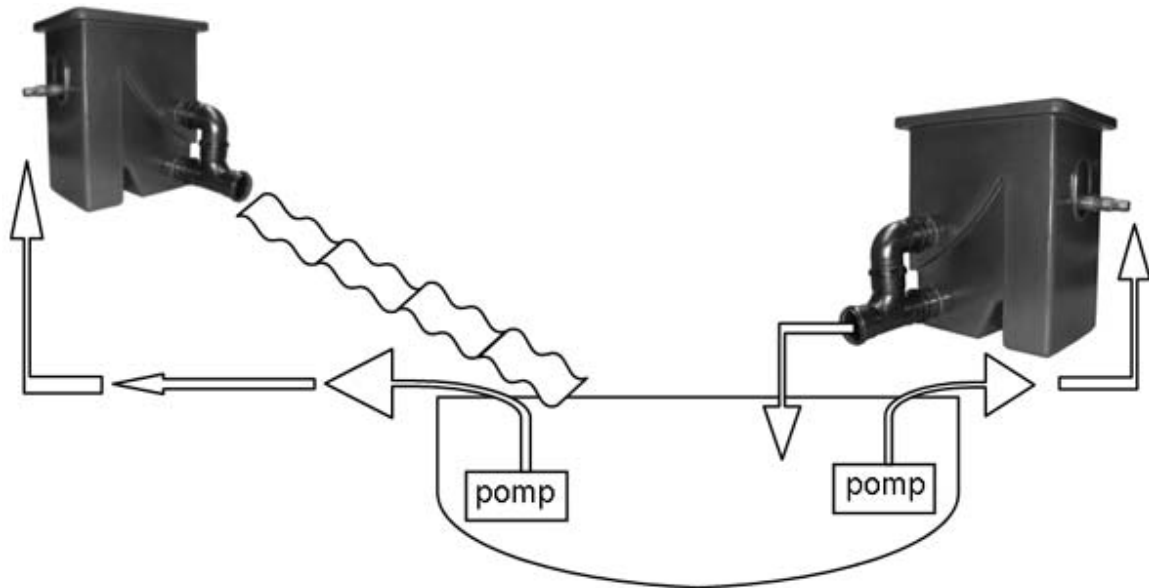

- As a mechanical particle waste pre-filter before surface mounted biological stages (B).

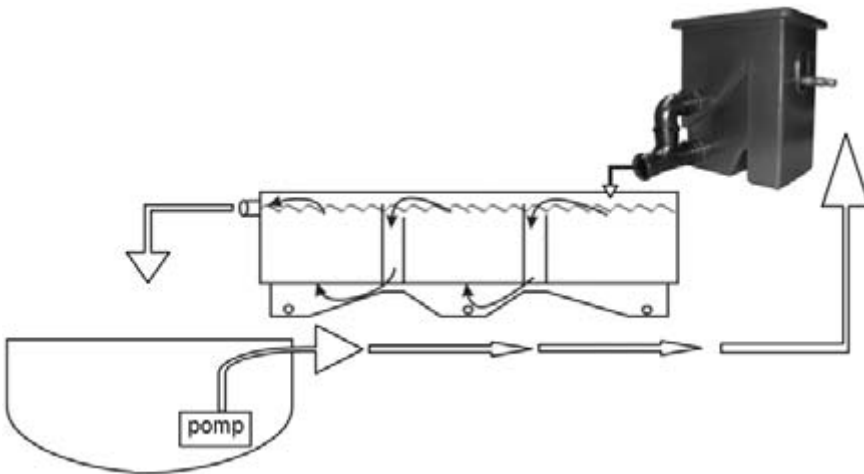

As a mechanical pre-filter for existing trickle filter systems (C).

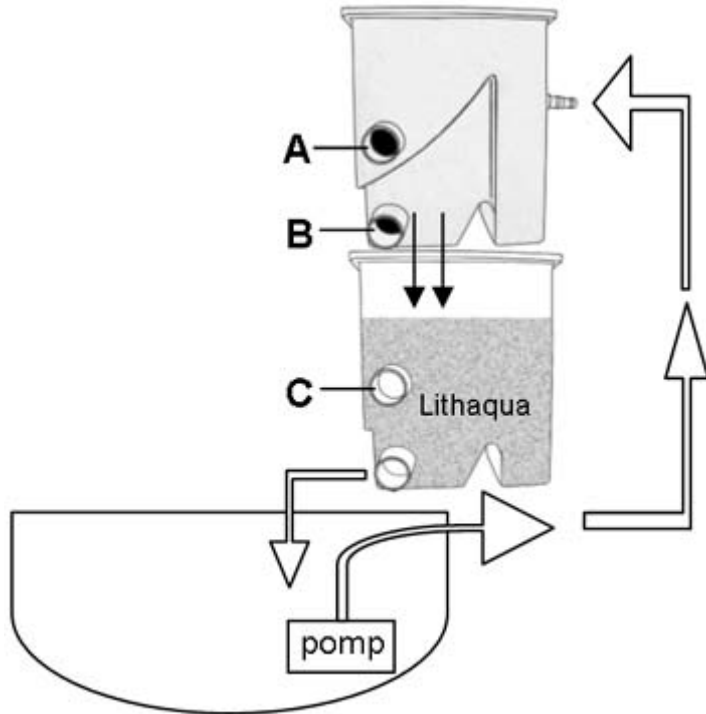

- The unit can be connected to a pond vacuum cleaner and the returned water from the vacuum cleaner can be fed into the input hose tail via a T-piece or directly. For extra particle removal and saving your precious matured pond water (D)

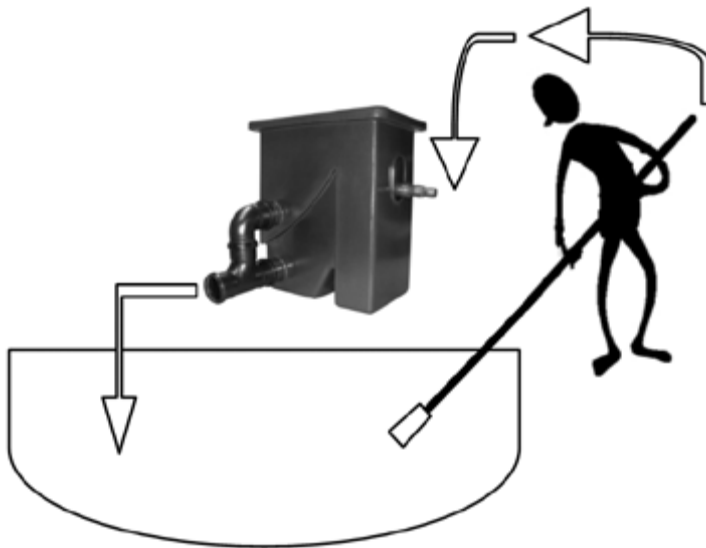

- The unit can be connected to an existing pumped pond skimmer system. The unit must be mounted above pond water level (E)

